



USB-Blaster Download Cable

User Guide



101 Innovation Drive
San Jose, CA 95134
(408) 544-7000
<http://www.altera.com>

UG-USB81204-1.2
P25-10325-01

Document Version: 1.2
Document Date: December 2004

Copyright © 2004 Altera Corporation. All rights reserved. Altera, The Programmable Solutions Company, the stylized Altera logo, specific device designations, and all other words and logos that are identified as trademarks and/or service marks are, unless noted otherwise, the trademarks and service marks of Altera Corporation in the U.S. and other countries. All other product or service names are the property of their respective holders. Altera products are protected under numerous U.S. and foreign patents and pending applications, maskwork rights, and copyrights. Altera warrants performance of its semiconductor products to current specifications in accordance with Altera's standard warranty, but reserves the right to make changes to any products and services at any time without notice. Altera assumes no responsibility or liability arising out of the application or use of any information, product, or service described herein except as expressly agreed to in writing by Altera Corporation. Altera customers are advised to obtain the latest version of device specifications before relying on any published information and before placing orders for products or services.



Printed on recycled paper



I.S. EN ISO 9001

Chapter 1. Setting Up the USB-Blaster Download Cable

Introduction	1-1
Device Support	1-1
Power Requirements	1-1
Software Requirements	1-2
Hardware Setup	1-2
Software Setup	1-3
Installing the USB-Blaster Driver	1-3
Setting Up the USB-Blaster Hardware in the Quartus II Software	1-5

Chapter 2. USB-Blaster Specifications

Overview	2-1
USB-Blaster Connections	2-1
Voltage Requirements	2-1
Cable-to-Board Connection	2-2
USB-Blaster Plug Connection	2-2
Circuit Board Header Connection	2-4
Operating Conditions	2-4
References	2-6
Revision History	2-7
How to Contact Altera	2-7



Chapter 1. Setting Up the USB-Blaster Download Cable

Introduction

The USB-Blaster™ download cable interfaces to a standard USB PC port. This cable drives configuration data from the PC to the device. Because design changes are downloaded directly to the device, prototyping is easy and multiple design iterations can be accomplished in quick succession.

Device Support

The USB-Blaster download cable allows you to program and configure Altera® devices. Specifically, you can do the following:

- Download configuration data to FPGA devices:
 - Stratix® II, Stratix GX, and Stratix family of devices
 - Cyclone™ II and Cyclone family of devices
 - APEX™ II and APEX 20K family of devices
 - ACEX® 1K devices
 - Mercury™ devices
 - FLEX™ 10K, FLEX 10KE, and FLEX 10KA family of devices
 - Excalibur™ devices
- Download configuration data to User Flash Memory (UFM) devices:
 - MAX® II family of devices
- Download configuration data to EEPROM-based devices:
 - MAX 3000 and MAX 7000 family of devices
- Perform in-system programming of advanced configuration devices:
 - EPC2, EPC4, EPC8, EPC16, and EPC1441 devices
- Perform in-system programming of serial configuration devices:
 - EPCS1, EPCS4, EPCS16,

Software Requirements

The USB-Blaster download cable is available only for Windows 2000 and Windows XP systems.

Use the Quartus® II software version 4.0 or later to configure your device. The USB-Blaster download cable also supports the following:

- Quartus II Programmer (for programming and configuration)
- Quartus II SignalTap® II Logic Analyzer (for logic analysis)
- Quartus II Programmer (standalone version)
- Quartus II SignalTap II logic analyzer (standalone version)

Hardware Setup

This section describes how to install and set up the USB-Blaster download cable for device configuration or programming.



For plug and header dimensions, pin names, and operating conditions, see Chapter 2, “USB-Blaster Specifications.”

Connect your USB-Blaster download cable to the circuit board as instructed below.

1. Disconnect the power cable from the circuit board.
2. Connect the USB cable to the USB port on your PC and to the USB-Blaster port.
3. Connect the USB-Blaster download cable to the 10-pin header on the device board. Figure 1–1 shows the USB-Blaster download cable and the circuit board connector.

To install the driver, follow the directions below:

1. For Window 2000, choose **Settings > Control Panel** (Windows Start menu).

or

For Windows XP, choose **Control Panel** (Windows Start menu).

2. Click **Switch to Classic View** if necessary (Control Panel window).
3. Double-click the **Add Hardware** icon to start the **Add Hardware** wizard and click **Next** to continue.
4. Select **Yes, I have already connected the hardware** and click **Next**.
5. Select **Add a new hardware device** from the **Installed hardware** list, and click **Next** to continue.
6. Select **Install from a list or specified location (Advanced)** and click **Next** to continue.



Depending on your system, the wording of this option may vary slightly.

7. Select **Sound, video and game controllers**, and click **Next** to continue.
8. Select **Have Disk** and browse to the location of the driver on your system: \<Quartus II system directory>**drivers\usb-blaster**
Click **OK**.
9. Select **Altera USB-Blaster** and click **Next** to continue.
10. Click **Next** to install the driver.
11. Click **Continue Anyway** when the Hardware Installation warning appears.
12. Click **Finish** in the Completing the Add/Remove Hardware Wizard window. Reboot your system.

Setting Up the USB-Blaster Hardware in the Quartus II Software

Use the following steps to set up the USB-Blaster hardware in the Quartus II software:

1. Start the Quartus II software.
2. Choose **Programmer** (Tools menu).
3. Click **Hardware Setup**. The **Hardware Settings** tab of the **Hardware Setup** dialog box is displayed. **USB-Blaster** is visible in the **Available hardware items** list of the **Hardware Setup** dialog box, as shown in Figure 1–2.

Figure 1–2. Hardware Setup Dialog Box

4. Click **USB-Blaster** to highlight it and then click the **Select Hardware** button.
5. Click **Close** to close the **Hardware Setup** dialog box.
6. In the **Mode** list, select the desired mode (Programmer window). Table 1–1 describes each mode.



The USB-Blaster supports the Joint Test Action Group (JTAG), Passive Serial Programming, and Active Serial modes.

Table 1–1. Programming Modes

Mode	Mode Description
Joint Test Action Group (JTAG)	Programs or configures all Altera devices supported by Quartus II software, excluding FLEX 6000.
In-Socket Programming	Not supported by the USB-Blaster.
Passive Serial Programming	Configures all Altera devices supported by Quartus II software excluding MAX 3000 and MAX 7000 devices.
Active Serial Programming	Programs a single EPCS1 or EPCS4 serial configuration device.



For details about programming devices and creating secondary programming files, see the “Programming & Configuration” chapter of the *Introduction to Quartus II Handbook*.

For further information, see the Programming module of the Quartus II online tutorial.

For further information, refer to the following topics in the Quartus II software Help menu:

- Changing the Hardware Setup
- Programmer Introduction
- Overview: Working with Chain Description Files
- Overview: Converting Programming Files

Overview

This chapter provides comprehensive information about the USB-Blaster™ download cable including the following:

- USB-Blaster connections
 - Voltage requirements
 - Cable-to-board connection
 - USB-Blaster plug connection
 - Circuit board header connection
- Operating conditions

USB-Blaster Connections

The USB-Blaster cable has a USB universal plug that connects to the PC USB port, and a 10-pin female plug that connects to the circuit board. Data is downloaded from the USB port on the PC through the USB-Blaster cable to the circuit board via the connections discussed in this section.

Voltage Requirements

The USB-Blaster VCC (TRGT) pin must be connected to a specific voltage for the device being programmed. Connect pull-up resistors to the same power supply as the USB-Blaster V_{CC(TRGT)}. See Table 2–1.

Device Family	USB-Blaster VCC Voltage Required
MAX II device	As specified by V _{CCIO} of Bank 1
MAX 7000S device	5 V
MAX 7000AE and MAX 3000A devices	3.3 V
MAX 7000B device	2.5 V
Stratix II, Stratix GX, and Stratix devices	As specified by V _{CCSEL}
Cyclone II, Cyclone, APEX II, APEX 20K, and Mercury devices	As specified by V _{CCIO}
FLEX 10K, FLEX 8000, and FLEX 6000 devices	5 V
FLEX 10KE device	2.5 V
FLEX 10KA and FLEX 6000A devices	3.3 V
EPC2 device	5 V or 3.3 V

Table 2-1. USB-Blaster VCC(TRGT) Pin Voltage Requirements (Part 2 of 2)	
EPC4, EPC8, and EPC16 devices	3.3 V
EPCS1 and EPCS4 devices	3.3 V

Cable-to-Board Connection

A standard USB cable connects to the USB port on the device. Figure 2-1 shows a block diagram of the USB-Blaster download cable.

Figure 2-1. USB-Blaster Block Diagram

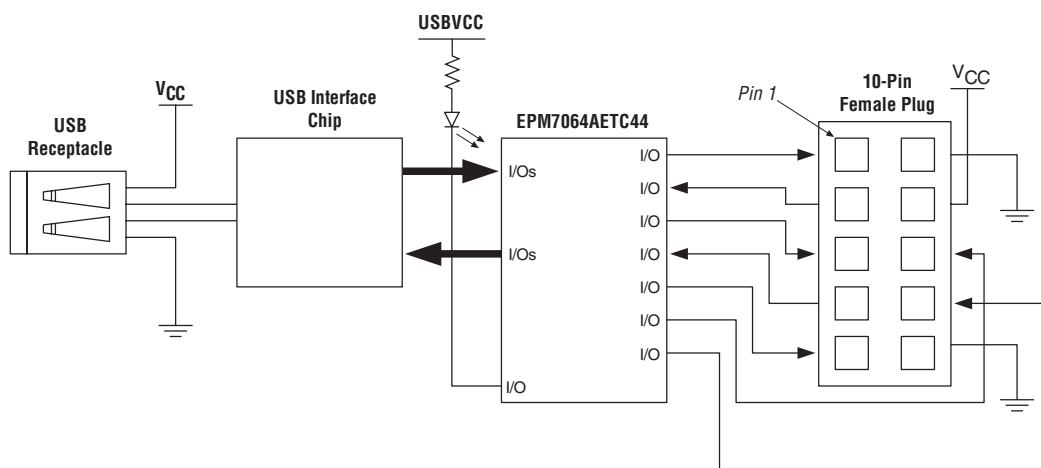

USB-Blaster Plug Connection

The 10-pin female plug connects to a 10-pin male header on the circuit board containing the target device. Figure 2-2 shows the dimensions of the female plug.

Figure 2–2. USB-Blaster 10-Pin Female Plug Dimensions

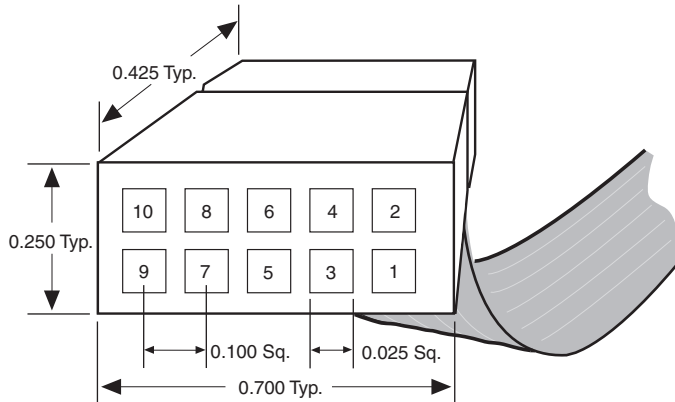

Dimensions are shown in inches. Spacing between pin centers is 0.1 inches.

Table 2–2 identifies the 10-pin female plug pin names and the corresponding programming mode.

Table 2–2. USB-Blaster Female Plug Signal Names & Programming Modes

Pin	AS Mode		PS Mode		JTAG Mode	
	Signal Name	Description	Signal Name	Description	Signal Name	Description
1	DCLK	Clock signal	DCLK	Clock signal	TCK	Clock signal
2	GND	Signal ground	GND	Signal ground	GND	Signal ground
3	CONF_DONE	Configuration done	CONF_DONE	Configuration done	TDO	Data from device
4	VCC (TRGT)	Target power supply	VCC (TRGT)	Target power supply	VCC (TRGT)	Target power supply
5	nCONFIG	Configuration control	nCONFIG	Configuration control	TMS	JTAG state machine control
6	nCE	Cyclone chip enable	–	No connect	–	No connect
7	DATAOUT	Active serial data out	nSTATUS	Configuration status	–	No connect
8	nCS	Serial configuration device chip select	–	No connect	–	No connect
9	ASDI	Active serial data in	DATA0	Data to device	TDI	Data to device
10	GND	Signal ground	GND	Signal ground	GND	Signal ground



The circuit board must supply $V_{CC(TRGT)}$ and ground to the USB-Blaster cable for the I/O drivers.

Circuit Board Header Connection

The circuit board's 10-pin male header, which connects to the USB-Blaster cable's 10-pin female plug, has two rows of five pins. These pins are connected to the device's programming or configuration pins. Figure 2–3 shows the dimensions of a typical 10-pin male header.

Figure 2–3. 10-Pin Male Header Dimensions

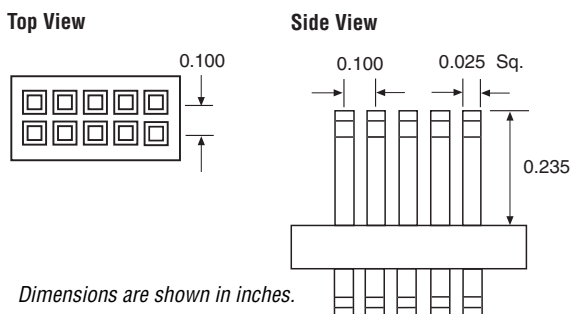

Operating Conditions

Tables 2–3 through 2–5 summarize the maximum ratings, recommended operating conditions, and DC operating conditions for the USB-Blaster cable.

Table 2–3. USB-Blaster Cable Absolute Maximum Ratings

Symbol	Parameter	Conditions	Min	Max	Unit
$V_{CC(TRGT)}$	Target supply voltage	With respect to ground	–0.3	5.5	V
$V_{CC(USB)}$	USB supply voltage	With respect to ground	–0.5	6.0	V
I_i	Input current	TDO or dataout	–10.0	10.0	mA
I_o	Output current	TCK, TMS, TDI, nCS, nCE	–20.0	20.0	mA

Table 2-4. USB-Blaster Cable Recommended Operating Conditions

Symbol	Parameter	Conditions	Min	Max	Unit
$V_{CC(TRGT)}$	Target supply voltage, 5.0-V operation		4.75	5.25	V
	Target supply voltage, 3.3-V operation		3.0	3.6	V
	Target supply voltage, 2.5-V operation		2.375	2.625	V
	Target supply voltage, 1.8-V operation		1.71	1.89	V
	Target supply voltage, 1.5-V operation		1.43	1.57	V

Table 2-5. USB-Blaster Cable DC Operating Conditions

Symbol	Parameter	Conditions	Min	Max	Unit
V_{IH}	High-level input voltage		$V_{CC(TRGT)} - 0.2$		V
V_{IL}	Low-level input voltage			0.15	V
V_{OH}	5.0-V high-level output voltage	$V_{CC(TRGT)} = 4.5\text{ V}, I_{OH} = 1\text{ mA}$	4.4		V
	3.3-V high-level output voltage	$V_{CC(TRGT)} = 3.0\text{ V}, I_{OH} = 1\text{ mA}$	2.9		V
	2.5-V high-level output voltage	$V_{CC(TRGT)} = 2.375\text{ V}, I_{OH} = 1\text{ mA}$	2.275		V
	1.8-V high-level output voltage	$V_{CC(TRGT)} = 1.71\text{ V}, I_{OH} = 1\text{ mA}$	1.61		V
	1.5-V high-level output voltage	$V_{CC(TRGT)} = 1.43\text{ V}, I_{OH} = 1\text{ mA}$	1.33		V
V_{OL}	5.0-V low-level output voltage	$V_{CC(TRGT)} = 5.5\text{ V}, I_{OL} = 1\text{ mA}$		0.125	V
	3.3-V low-level output voltage	$V_{CC(TRGT)} = 3.6\text{ V}, I_{OL} = 1\text{ mA}$		0.125	V
	2.5-V low-level output voltage	$V_{CC(TRGT)} = 2.625\text{ V}, I_{OL} = 1\text{ mA}$		0.125	V
	1.8-V low-level output voltage	$V_{CC(TRGT)} = 1.89\text{ V}, I_{OL} = 1\text{ mA}$		0.125	V
	1.5-V low-level output voltage	$V_{CC(TRGT)} = 1.57\text{ V}, I_{OL} = 1\text{ mA}$		0.125	V
$I_{CC(USB)}$	Operating current (No Load)	(Typical $I_{CC(USB)} = 80\text{ mA}$)		150	mA

References

For more information on configuration and in-system programmability (ISP), see the following sources:

- *AN 39: IEEE 1149.1 (JTAG) Boundary-Scan Testing in Altera Devices*
- *AN 95: In-System Programmability in MAX Devices*
- *AN 250: Configuring Cyclone FPGAs*
- “Configuring Stratix II Devices” chapter in Volume 2 of the *Stratix II Device Handbook*
- “Configuring Stratix and Stratix GX Devices” chapter in the *Stratix Device Handbook*
- “Configuring Cyclone II Devices” chapter in the *Cyclone II Handbook*
- *Serial Configuration Devices Data Sheet*
- “Programming & Configuration” chapter in the *Introduction to Quartus II* manual
- The Programming module of the Quartus II online tutorial
- Refer to the following glossary definitions in the Quartus II Help:
 - “USB-Blaster Cable” (general description)
 - “Configuration scheme” (general description)
 - “Programming files” (general description)
- Refer to the following procedures in the Quartus II Help:
 - Programming a Single Device or Multiple Devices in JTAG or Passive Serial Mode
 - Programming a Single Device in Active Serial Programming Mode
- Refer to the following introduction and overview topics in the Quartus II Help:
 - Programmer Introduction
 - Overview: Working with Chain Description Files
 - Overview: Converting Programming Files

Revision History

The table below shows the revision history of this user guide.

Chapter	Date	Version	Changes Made
2	December 2004	1.2	Update to conditions in table 2-5.
All	November 2004	1.1	Re-release.
All	July 2004	1.0	Initial release.

How to Contact Altera

For the most up-to-date information about Altera products, go to the Altera world-wide web site at www.altera.com. For technical support on this product, go to www.altera.com/mysupport. For additional information about Altera products, consult the sources shown below.

Information Type	USA & Canada	All Other Locations
Technical support	www.altera.com/mysupport/	www.altera.com/mysupport/
	(800) 800-EPLD (3753) (7:00 a.m. to 5:00 p.m. Pacific Time)	(408) 544-7000 (1) (7:00 a.m. to 5:00 p.m. Pacific Time)
Product literature	www.altera.com	www.altera.com
Altera literature services	lit_req@altera.com (1)	lit_req@altera.com (1)
Non-technical customer service	(800) 767-3753 (7:00 a.m. to 5:00 p.m. Pacific Time)	(408) 544-7000 (7:00 a.m. to 5:00 p.m. Pacific Time)
FTP site	ftp.altera.com	ftp.altera.com

Note to table:

(1) You can also contact your local Altera sales office or sales representative.

